

SCALE™-2 2SC0535T

Preliminary Description and Application Manual

Dual-Channel Cost-Efficient Driver Core for IGBTs up to 3300V

Abstract

The 2SC0535T dual-channel SCALE™-2 driver core combines unrivalled compactness with broad applicability and cost efficiency. It is designed for industrial and traction applications requiring high reliability. The 2SC0535T drives all usual high-voltage IGBT modules up to 3300V. Its embedded paralleling capability allows easy inverter design covering higher power ratings. Multi-level topologies involving 1700V IGBTs with higher isolation requirements can also be easily supported by 2SC0535T.

The 2SC0535T is the most compact driver core in its voltage and power range, featuring a footprint of only 76.5 x 59.2mm and an insertion height of maximum 26mm. It allows even the most restricted insertion spaces to be efficiently used.



Fig. 1 2SC0535T driver core

 Preliminary Description & Application Manual

Contents

Abstract	1
Contents	2
Driver Overview	4
Mechanical Dimensions	5
Pin Designation	7
Recommended Interface Circuitry for the Primary-Side Connector	8
Description of Primary-Side Interface	8
General.....	8
VCC terminal	8
VDC terminal.....	9
MOD (mode selection)	9
INA, INB (channel drive inputs, e.g. PWM).....	10
SO1, SO2 (status outputs).....	10
TB (input for adjusting the blocking time T_b).....	10
Recommended Interface Circuitry for the Secondary-Side Connectors	11
Description of Secondary-Side Interfaces	11
General.....	11
DC/DC output (VISOx), emitter (VEx) and COMx terminals.....	12
Reference terminal (REFx).....	12
Collector sense (VCEx)	12
Active clamping (ACLx)	14
Gate turn-on (GHx) and turn-off (GLx) terminals	15
How Do 2SC0535T SCALE-2 Drivers Work in Detail?	16
Power supply and electrical isolation	16
Power-supply monitoring.....	16
V_{CE} monitoring / short-circuit protection.....	16
Desaturation protection with sense diodes	17
Parallel connection of 2SC0535T	17
3-level or multilevel topologies.....	17
Bibliography	17
The Information Source: SCALE-2 Driver Data Sheets	18
Quite Special: Customized SCALE-2 Drivers	18
Technical Support	18
Quality	18
Legal Disclaimer	18
Ordering Information	19

Preliminary Description & Application Manual

Information about Other Products 19
Manufacturer..... 19
Power Integrations Worldwide High Power Customer Support Locations..... 20

Preliminary Description & Application Manual

Driver Overview

The 2SC0535T is a driver core equipped with Power Integrations' latest SCALE-2 chipset /1/. The SCALE-2 chipset is a set of application-specific integrated circuits (ASICs) that cover the main range of functions needed to design intelligent gate drivers. The SCALE-2 driver chipset is a further development of the proven SCALE™-1 technology /2/.

The 2SC0535T targets medium- and high-power, dual-channel IGBT applications up to 3300V. The driver supports switching up to 100kHz at best-in-class efficiency. The 2SC0535T comprises a complete dual-channel IGBT driver core, fully equipped with an isolated DC/DC converter, short-circuit protection, Advanced Active Clamping and supply-voltage monitoring.

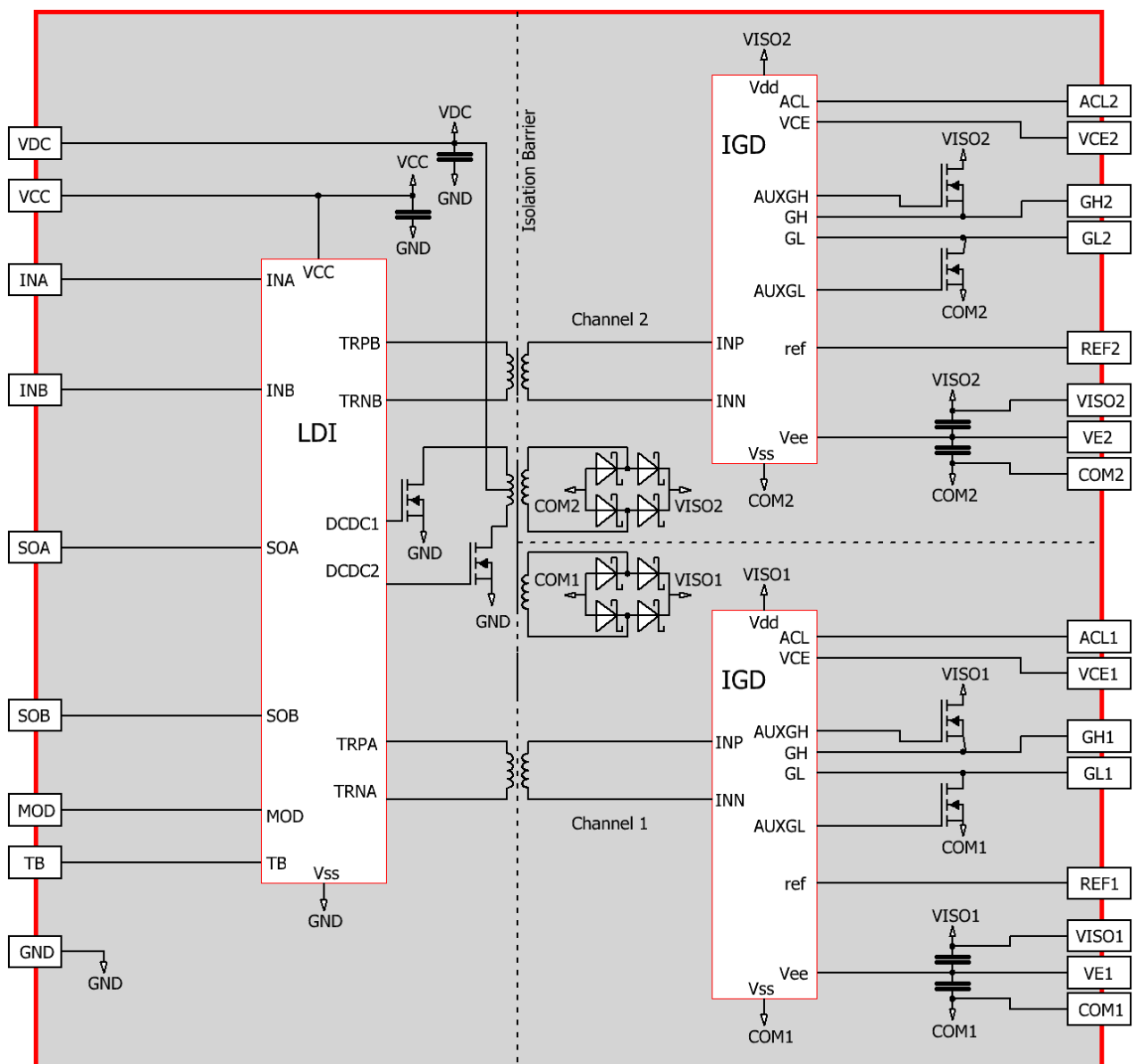

Fig. 2 Block diagram of the driver core 2SC0535T

Mechanical Dimensions

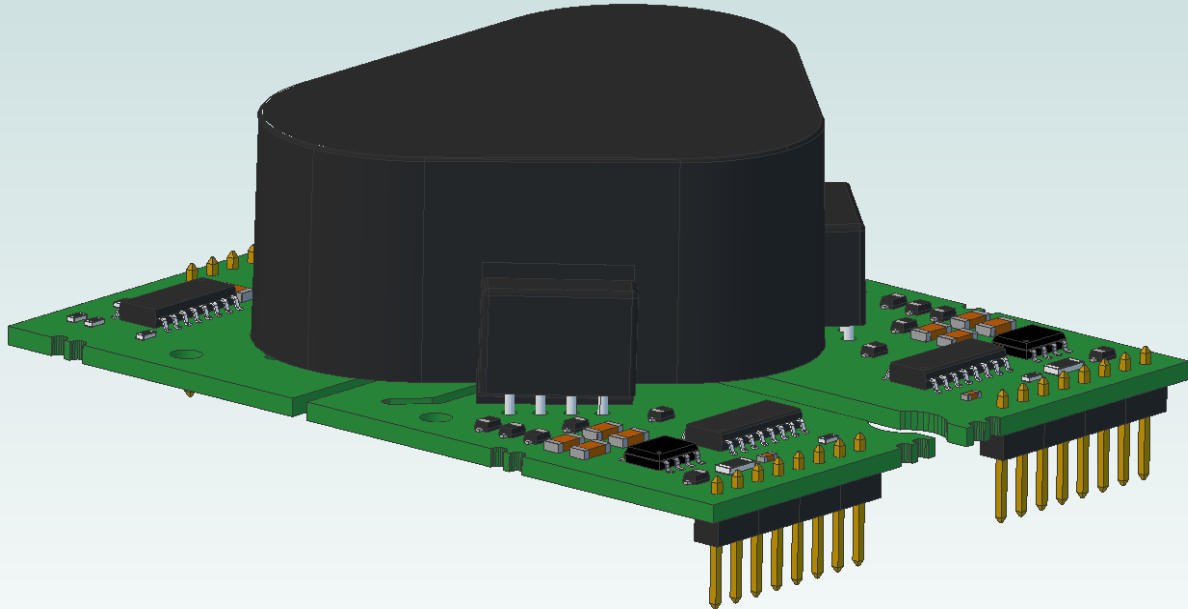

Fig. 3 Interactive 3D drawing of 2SC0535T2Ax-33

Preliminary Description & Application Manual

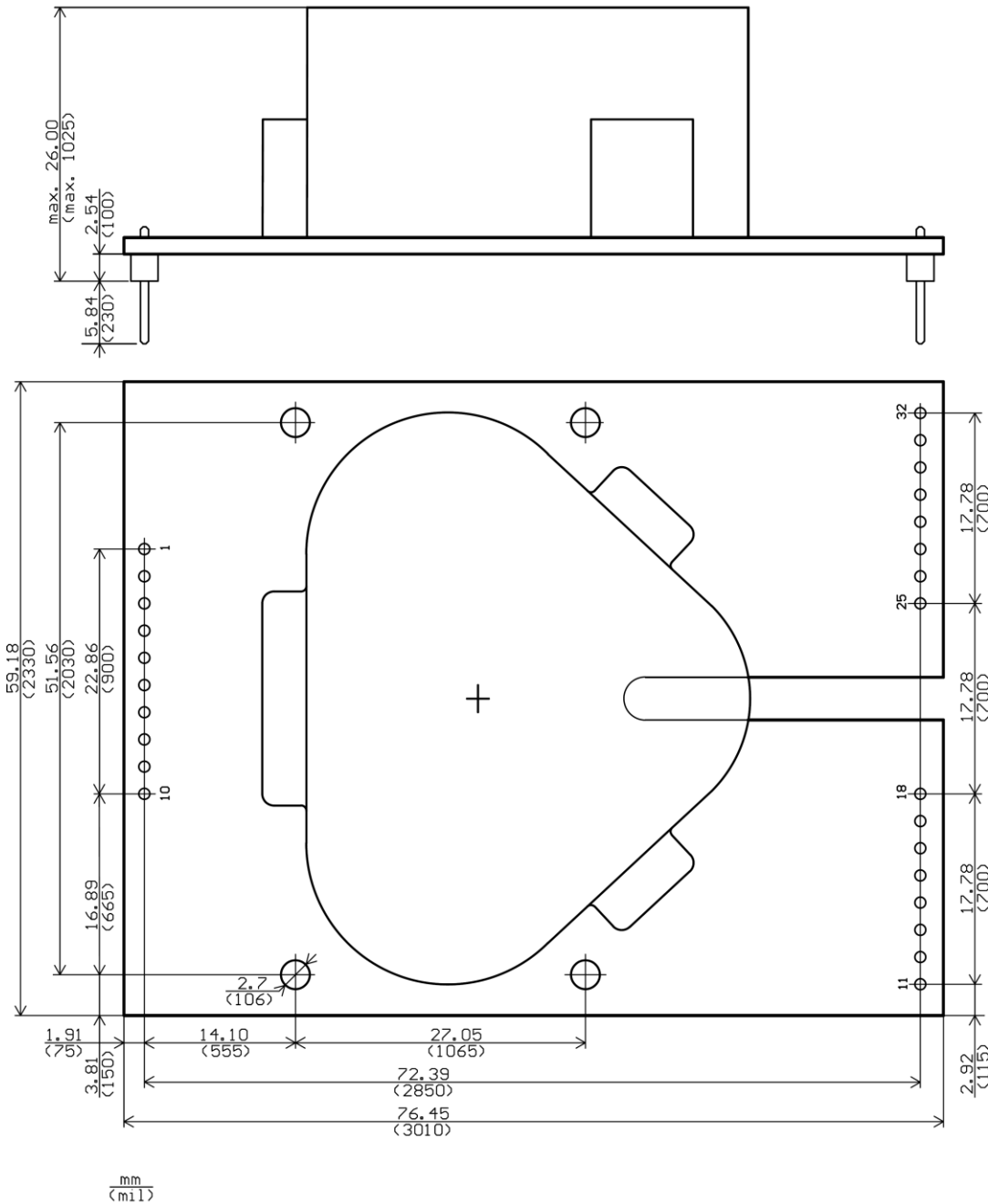

Fig. 4 Mechanical drawing of 2SC0535T2Ax-33

The primary side and secondary side pin grid is 2.54mm (100mil) with a pin cross section of 0.64mm x 0.64mm. Total outline dimensions of the board are 59.2mm x 76.5mm. The total height of the driver is maximum 26mm measured from the bottom of the pin bodies to the top of the populated PCB.

Note that the mechanical fixing points are placed in the clearance and creepage paths. Insulated fixation material (screws, distance bolts) must therefore be used in order not to reduce these.

Recommended diameter of solder pads: Ø 2mm (79 mil)

Recommended diameter of drill holes: Ø 1mm (39 mil)

Preliminary Description & Application Manual

Pin Designation

Pin No. and Name	Function
Primary Side	
1 VDC	DC/DC converter supply
2 SO1	Status output channel 1; normally high-impedance, pulled down to low on fault
3 SO2	Status output channel 2; normally high-impedance, pulled down to low on fault
4 MOD	Mode selection (direct/half-bridge mode)
5 TB	Set blocking time
6 VCC	Supply voltage; 15V supply for primary side
7 GND	Ground
8 INA	Signal input A; non-inverting input relative to GND
9 INB	Signal input B; non-inverting input relative to GND
10 GND	Ground
Secondary Sides	
11 GL1	Gate low channel 1; pulls gate low through turn-off resistor
12 GH1	Gate high channel 1; pulls gate high through turn-on resistor
13 COM1	Secondary-side ground channel 1
14 VE1	Emitter channel 1; connect to (auxiliary) emitter of power switch
15 VISO1	DC/DC output channel 1
16 REF1	Set V_{CE} detection threshold channel 1; resistor to VE1
17 VCE1	V_{CE} sense channel 1; connect to IGBT collector through impedance network
18 ACL1	Active clamping feedback channel 1; leave open if not used
19 Free	
20 Free	
21 Free	
22 Free	
23 Free	
24 Free	
25 ACL2	Active clamping feedback channel 2; leave open if not used
26 VCE2	V_{CE} sense channel 2; connect to IGBT collector through impedance network
27 REF2	Set V_{CE} detection threshold channel 2; resistor to VE2
28 VISO2	DC/DC output channel 2
29 VE2	Emitter channel 2; connect to (auxiliary) emitter of power switch
30 COM2	Secondary-side ground channel 2
31 GH2	Gate high channel 2; pulls gate high through turn-on resistor
32 GL2	Gate low channel 2; pulls gate low through turn-off resistor

Note: Pins with the designation "Free" are not physically present.

Preliminary Description & Application Manual

Recommended Interface Circuitry for the Primary-Side Connector

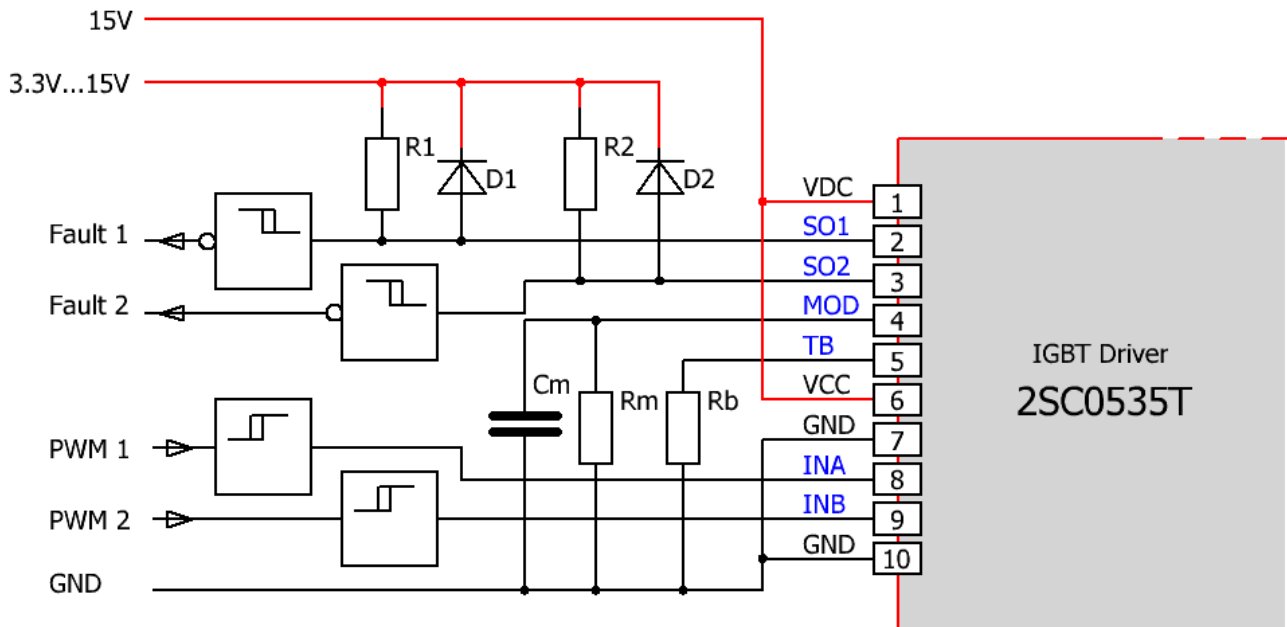

Fig. 5 Recommended user interface of 2SC0535T (primary side)

Both ground pins must be connected together with low parasitic inductance. A common ground plane or wide tracks are strongly recommended. The connecting distance between ground pins must be kept at a minimum.

Description of Primary-Side Interface

General

The primary-side interface of the driver 2SC0535T is very simple and easy to use.

The driver primary side is equipped with a 10-pin interface connector with the following terminals:

- 2 x power-supply terminals
- 2 x drive signal inputs
- 2 x status outputs (fault returns)
- 1 x mode selection input (half-bridge mode / direct mode)
- 1 x input to set the blocking time

All inputs and outputs are ESD-protected. Moreover, all digital inputs have Schmitt-trigger characteristics.

VCC terminal

The driver has one VCC terminal on the interface connector to supply the primary-side electronics with 15V.

Preliminary Description & Application Manual

VDC terminal

The driver has one VDC terminal on the interface connector to supply the DC-DC converters for the secondary sides.

VDC should be supplied with 15V. It is recommended to connect the VCC and VDC terminals to a common 15V power supply. In this case the driver limits the inrush current at startup and no external current limitation of the voltage source for VDC is needed.

MOD (mode selection)

The MOD input allows the operating mode to be selected with a resistor connected to GND.

Direct mode

If the MOD input is connected to GND, direct mode is selected. In this mode, there is no interdependence between the two channels. Input INA directly influences channel 1 while INB influences channel 2. High level at an input (INA or INB) always results in turn-on of the corresponding IGBT. In a half-bridge topology, this mode should be selected only when the dead times are generated by the control circuitry so that each IGBT receives its own drive signal.

Caution: Synchronous or overlapping timing of both switches of a half-bridge basically shorts the DC-link.

Half-bridge mode

If the MOD input is connected to GND with a resistor $72\text{k}\Omega < R_m < 181\text{k}\Omega$, half-bridge mode is selected. In this mode, the inputs INA and INB have the following functions: INA is the drive signal input while INB acts as the enable input (see Fig. 6). It is recommended to place a capacitor $C_m = 22\text{nF}$ in parallel to R_m in order to reduce the deviation between the dead times at the rising and falling edges of INA respectively.

When input INB is low level, both channels are blocked. If it goes high, both channels are enabled and follow the signal on the input INA. At the transition of INA from low to high, channel 2 turns off immediately and channel 1 turns on after a dead time T_d .

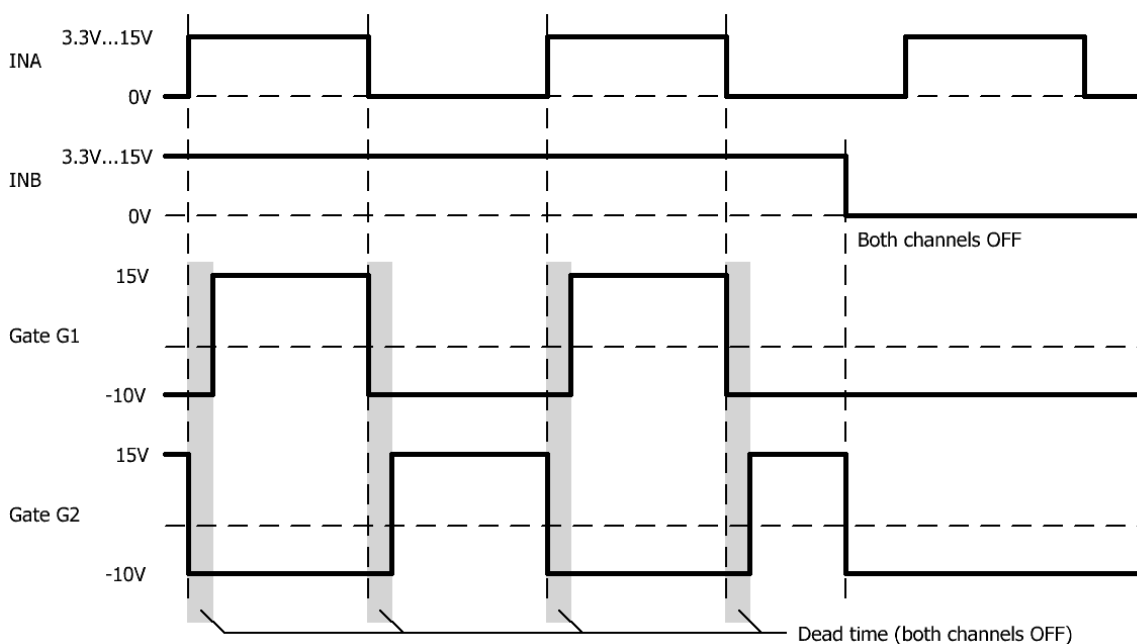

Fig. 6 Signals in half-bridge mode

Preliminary Description & Application Manual

The value of the dead time T_d is determined by the value of the resistor R_m according to the following formula (typical value):

$$R_m [k\Omega] = 31.5 \cdot T_d [\mu s] + 52.7 \quad \text{with } 0.6\mu s < T_d < 4.1\mu s \text{ and } 72k\Omega < R_m < 181k\Omega$$

Note that the dead time may vary from sample to sample. A tolerance of approximately $\pm 20\%$ may be expected. If higher timing precisions are required, Power Integrations recommends using the direct mode and generating the dead time externally (refer to the Application Note AN-1101 /4/).

INA, INB (channel drive inputs, e.g. PWM)

INA and INB are basically drive inputs, but their function depends on the MOD input (see above). They safely recognize signals in the whole logic-level range between 3.3V and 15V. Both input terminals feature Schmitt-trigger characteristics (refer to the driver data sheet /3/). An input transition is triggered at any edge of an incoming signal at INA or INB.

SO1, SO2 (status outputs)

The outputs SOx have open-drain transistors. When no fault condition is detected, the outputs have high impedance. An internal current source of 500 μ A pulls the SOx outputs to a voltage of about 4V when leaved open. When a fault condition (primary-side supply undervoltage, secondary-side supply undervoltage, IGBT short-circuit or overcurrent) is detected, the corresponding status output SOx goes to low (connected to GND).

The diodes D_1 and D_2 must be Schottky diodes and must only be used when using 3.3V logic. For 5V...15V logic, they can be omitted.

The maximum SOx current in a fault condition must not exceed the value specified in the driver data sheet /3/.

Both SOx outputs can be connected together to provide a common fault signal (e.g. for one phase). However, it is recommended to evaluate the status signals individually to allow fast and precise fault diagnosis.

How the status information is processed

- A fault on the secondary side (detection of short-circuit of IGBT module or supply undervoltage) is transmitted to the corresponding SOx output immediately. The SOx output is automatically reset (returning to a high impedance state) after the blocking time T_b has elapsed (refer to "TB (input for adjusting the blocking time T_b)" for timing information).
- A supply undervoltage on the primary side is indicated to both SOx outputs at the same time. Both SOx outputs are automatically reset (returning to a high impedance state) when the undervoltage on the primary side disappears.

TB (input for adjusting the blocking time T_b)

The terminal TB allows the blocking time to be set by connecting a resistor R_b to GND (see Fig. 5). The following equation calculates the value of R_b connected between pins TB and GND in order to program the desired blocking time T_b (typical value):

$$R_b [k\Omega] = 1.0 \cdot T_b [ms] + 51 \quad \text{with } 20ms < T_b < 130ms \text{ and } 71k\Omega < R_b < 181k\Omega$$

The blocking time can also be set to a minimum of 9 μ s (typical value) by selecting $R_b=0\Omega$. The terminal TB must not be left floating.

Preliminary Description & Application Manual

Note: It is also possible to apply a stabilized voltage at TB. The following equation is used to calculate the voltage V_b between TB and GND in order to program the desired blocking time T_b (typical value):

$$V_b[V] = 0.02 \cdot T_b[ms] + 1.02 \quad \text{with} \quad 20ms < T_b < 130ms \text{ and } 1.42 < V_b < 3.62V$$

Recommended Interface Circuitry for the Secondary-Side Connectors

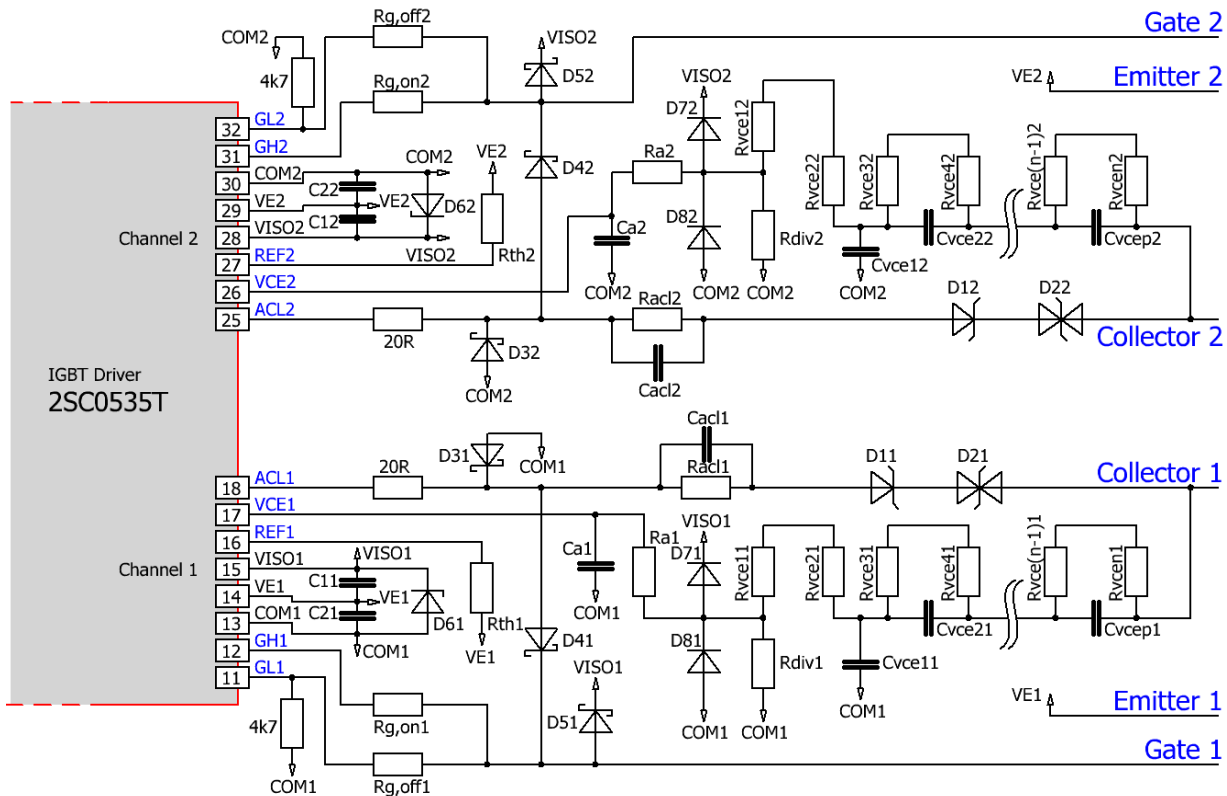

Fig. 7 Recommended user interface of 2SC0535T (secondary sides)

Description of Secondary-Side Interfaces

General

Each driver's secondary side (driver channel) is equipped with an 8-pin interface connector with the following terminals (x stands for the number of the drive channel 1 or 2):

- 1 x DC/DC output terminal VISOx
- 1 x DC/DC output terminal COMx
- 1 x emitter terminal VEx
- 1 x reference terminal REFx for overcurrent or short-circuit protection
- 1 x collector sense terminal VCEx
- 1 x active clamping terminal ACLx
- 1 x turn-on gate terminals GHx
- 1 x turn-off gate terminals GLx

All inputs and outputs are ESD-protected.

Preliminary Description & Application Manual

DC/DC output (VISOx), emitter (VEx) and COMx terminals

The driver is equipped with blocking capacitors on the secondary side of the DC/DC converter (for values, refer to the data sheet /3/).

It is recommended to insert an external capacitance of 9.4µF between the VISOx and VEx terminals (C_{1x} in Fig. 7) to drive IGBT modules with a gate charge of up to 4.7µC.

For IGBTs with a higher gate charge, the following additional minimum blocking capacitance values are required for every 1µC gate charge beyond 4.7µC:

- 4µF per 1µC between VISOx and VEx (C_{1x} in Fig. 7) as well as
- 2µF per 1µC between VEx and COMx (C_{2x} in Fig. 7)

It is recommended to use double the overall capacitance value between VISOx and VEx than between VEx and COMx, including that already assembled on the driver.

The blocking capacitors must be connected as closely as possible to the driver's terminal pins with minimum inductance. Ceramic capacitors with a dielectric strength >20V are recommended.

If the capacitance C_{1x} (resp. C_{2x}) exceeds 200µF (resp. 100µF), please contact Power Integrations' support service.

No static load must be applied between VISOx and VEx, or between VEx and COMx. A static load can be applied between VISOx and COMx if necessary.

A 27V Zener diode with 2% tolerance (e.g. BZX384-B27 from NXP) must be placed between VISOx and COMx (D6x in Fig. 7). Note that future versions of the 2SC0535T with PCB number CT-271-3 or higher will include the Zener diode on the driver core. No external Zener diode is then required.

Reference terminal (REFx)

The reference terminal REFx allows the threshold to be set for short-circuit and/or overcurrent protection with a resistor placed between REFx and VEx. A constant current of 150µA is provided at pin REFx.

Collector sense (VCEx)

The collector sense must be connected to the IGBT collector with the circuit shown in Fig. 7 in order to detect an IGBT overcurrent or short circuit.

General information and recommendations:

- It is recommended to dimension the overall value of the resistors

$$R_{toix} = \sum_{i=1}^n R_{vceix} = R_{vce1x} + \dots + R_{vceix}$$

in order for a current of about 0.6...0.8mA to flow through

them at the maximum DC-link voltage. This current must not exceed 0.8mA. It is recommended to use series-connected resistors; the minimum creepage and clearance distances required for the application must be considered and the maximum voltage, power and temperature rating of the resistors used must not be exceeded. Dimensioning recommendations are given below.

- All resistors R_{vceix} ($i \geq 1$) must have the same value.
- R_{divx} allows the static threshold detection level V_{CEthx} to be increased if required (resistive voltage divider with R_{toix}). R_{divx} can be calculated as follows in order to determine the static detection level V_{CEthx} :

Preliminary Description & Application Manual

$$R_{divx} [k\Omega] = R_{totx} [k\Omega] \cdot \frac{V_{thx} [V] + |V_{GLx} [V]|}{V_{CEthx} [V] - V_{thx} [V]} \quad (V_{CEthx} > V_{thx})$$

$|V_{GLx}|$ is the absolute value of the gate-emitter turn-off voltage at the driver output. It depends on the driver load and can be found in the driver data sheet /3/. V_{thx} is the reference value set at the reference terminal REFx as described in the "Reference terminal (REFx)" section.

- The recommended range for the overall capacitance value is $C_{totx} = \frac{1}{\sum_{k=1}^p \frac{1}{C_{vcekx}}} = 1pF \dots 4pF$.
- All capacitances C_{vcekx} with $k \geq 2$ must have the same value.
- The capacitance C_{vce1x} must be chosen such that the following equation is fulfilled:

$$\frac{C_{vce1x}}{C_{totx}} = (0.7 \dots 0.9) \cdot \frac{R_{totx}}{R_{vce1x} + R_{vce2x}}$$
 The maximum voltage rating of the capacitors used must not be exceeded. Dimensioning recommendations are given below.
- The diodes D_{7x} and D_{8x} must have a very low leakage current and a blocking voltage of $> 40V$ (e.g. BAS416). Schottky diodes must be explicitly avoided.
- R_{ax} and C_{ax} are used to set the response time.

Recommended values for 3300V IGBTs with DC-link voltages up to 2200V

- $R_{vce1x} = R_{vce2x} = \dots = R_{vce14x} = 220k\Omega$ (500mW, 400V_{peak}, 1%)
- $R_{divx} = 1.5M\Omega$ (0603, 1%)
- $C_{vce1x} = 15pF$ (C0G, 5%, 1000V)
- $C_{vce2x} = C_{vce3x} = \dots = C_{vce7x} = 22pF$ (C0G, 630V, 5%)
- $C_{ax} = 33pF$ (C0G, 50V, 5%)
- $R_{thx} = 68k\Omega$ (0603, 1%)
- $R_{ax} =$ see Table 1 below (0603, 1%)

This setup uses 14 resistors R_{vceix} and 7 capacitors C_{vcekx} per channel and leads to a static desaturation detection threshold of about 50V.

V_{DC}	$R_a = 68k\Omega$	$R_a = 91k\Omega$	$R_a = 120k\Omega$
2200V	5.3 μ s	7.0 μ s	9.0 μ s
1500V	5.3 μ s	7.0 μ s	9.0 μ s
1100V	5.4 μ s	7.0 μ s	9.1 μ s
700V	7.6 μ s	8.1 μ s	9.3 μ s
600V	17.0 μ s	14.4 μ s	13.7 μ s

Table 1 Typical response time as a function of the resistance R_{ax} and the DC-link voltage V_{DC}

Table 1 gives indicative values only. The response time depends on the specific layout and the IGBT module used. It is therefore recommended to measure the short-circuit duration in the final design.

Preliminary Description & Application Manual

Note that slow IGBT modules may report a wrong V_{CE} desaturation fault at turn-on. It is therefore recommended to test the setup under worst case conditions (maximum DC-link voltage, maximum collector current and highest IGBT junction temperature). Please also refer to AN-1101 /4/ for more information.

Recommended values for 1700V IGBTs with DC-link voltages up to 1200V

- $R_{vce1x}=R_{vce2x}=...=R_{vce6x}=300k\Omega$ (500mW, 400V_{peak}, 1%)
- R_{divx} =not assembled
- C_{vceix} =not assembled
- D_{8x} =not assembled
- $R_{thx}=68k\Omega$ (0603, 1%)
- $R_{ax}=120k\Omega$ (0603, 1%)
- C_{ax} =see Table 2 below (0603, 5%)

This setup uses 6 resistors R_{vceix} per channel and leads to a static desaturation detection threshold of about 10.2V.

C_{ax} [pF]	Response time [μs]
0	1.5
15	4.9
22	6.5
33	8.9
47	12.2

Table 2 Typical response time as a function of the capacitance C_{ax}

Table 2 gives indicative values only. The response time depends on the specific layout and the IGBT module used. It is therefore recommended to measure the short-circuit duration in the final design.

Note that slow IGBT modules may report a wrong V_{CE} desaturation fault at turn-on. It is therefore recommended to test the setup under worst case conditions (maximum DC-link voltage, maximum collector current and highest IGBT junction temperature). Please also refer to AN-1101 /4/ for more information.

Note that the response time can increase with decreasing DC-link voltage values.

For more details about the functionality of this feature, refer to "VCE monitoring / short-circuit protection" on page 16.

Active clamping (ACLx)

Active clamping is a technique designed to partially turn on the power semiconductor as soon as the collector-emitter voltage exceeds a predefined threshold. The power semiconductor is then kept in linear operation.

Basic active clamping topologies implement a single feedback path from the IGBT's collector through transient voltage suppressor devices (TVS) to the IGBT gate. The 2SC0535T supports Power Integrations' Advanced Active Clamping, where the feedback is also provided to the driver's secondary side at pin ACLx: as soon as the voltage on the right side of the 20 Ω resistor (see Fig. 7) exceeds about 1.3V, the turn-off MOSFET is progressively switched off in order to improve the effectiveness of the active clamping and to reduce the losses in the TVS. The turn-off MOSFET is completely off when the voltage on the right side of the 20 Ω resistors (see Fig. 7) approaches 20V (measured to COMx).

It is recommended to use the circuit shown in Fig. 7. The following parameters must be adapted to the application:

Preliminary Description & Application Manual

- TVS D_{1x} , D_{2x} : it is recommended to use:
 - 1700V IGBTs with DC-link voltages up to 1200V: Five unidirectional 220V TVS and one bidirectional 220V TVS. Good clamping results can be obtained with five unidirectional TVS P6SMB220A and one bidirectional TVS P6SMB220CA from Diotec or five unidirectional TVS SMBJ188A-E3 and one bidirectional TVS SMBJ188CA-E3 from Vishay.
 - 3300V IGBTs with DC-link voltages up to 2200V: Seven unidirectional 300V TVS and one bidirectional 350V TVS. Good clamping results can be obtained with seven unidirectional TVS P6SMB300A and one bidirectional TVS P6SMB350CA from Diotec.

At least one bidirectional TVS (D_{2x}) per channel ($\geq 220V$ for 1700V IGBTs and $\geq 300V$ for 3300V IGBTs) must be used in order to avoid negative current flowing through the TVS chain during turn-on of the antiparallel diode of the IGBT module due to its forward recovery behavior. Such a current could, depending on the application, lead to undervoltage of the driver secondary voltage V_{ISOx} to V_{Ex} (15V).

Note that it is possible to modify the number of TVS in a chain. The active clamping efficiency can be improved by increasing the number of TVS used in a chain if the total breakdown voltage remains at the same value. Note also that the active clamping efficiency is highly dependent on the type of TVS used (e.g. manufacturer).

- R_{aclx} and C_{aclx} : These parameters allow the effectiveness of the active clamping as well as the losses in the TVS and the IGBT to be optimized. It is recommended to determine the value with measurements in the application. Typical values are: $R_{aclx}=0\dots 150\Omega$ and $R_{aclx}*C_{aclx}=100ns\dots 500ns$. $R_{aclx}=0\Omega$ is recommended to improve the effectiveness of active clamping (usually recommended).
- D_{3x} , D_{4x} and D_{5x} : it is recommended to use Schottky diodes with blocking voltages $>35V$ ($>1A$ depending on the application).

Please note that the 20Ω resistor as well as diodes D_{3x} , D_{4x} and D_{5x} must not be omitted if Advanced Active Clamping is used. If Advanced Active Clamping is not used, the 20Ω resistor as well as diodes D_{3x} and D_{4x} can be omitted. The pin $ACLx$ must then be left open.

Gate turn-on (GHx) and turn-off (GLx) terminals

These terminals allow the turn-on (GHx) and turn-off (GLx) gate resistors to be connected to the gate of the power semiconductor. The GHx and GLx pins are available as separated terminals in order to set the turn-on and turn-off resistors independently without the use of an additional diode. Please refer to the driver data sheet /3/ for the limit values of the gate resistors used.

A resistor between GLx and COMx of $4.7k\Omega$ (other values are also possible) may be used in order to provide a low-impedance path from the IGBT gate to the emitter/source even if the driver is not supplied with power. No static load (e.g. resistors) must be placed between GLx and the emitter terminal V_{Ex} .

Note however that it is not advisable to operate the power semiconductors within a half-bridge with a driver in the event of a low supply voltage. Otherwise, a high rate of increase of V_{CE} may cause partial turn-on of these IGBTs.

Preliminary Description & Application Manual

How Do 2SC0535T SCALE-2 Drivers Work in Detail?

Power supply and electrical isolation

The driver is equipped with a DC/DC converter to provide an electrically insulated power supply to the gate driver circuitry. All transformers (DC/DC and signal transformers) feature safe isolation to EN 50178, protection class II as well as EN 50124 between primary side and either secondary side.

Note that the driver requires a stabilized supply voltage.

Power-supply monitoring

The driver's primary side as well as both secondary-side driver channels are equipped with a local undervoltage monitoring circuit.

In the event of a primary-side supply undervoltage, the power semiconductors are driven with a negative gate voltage to keep them in the off-state (the driver is blocked) and the fault is transmitted to both outputs SO1 and SO2 until the fault disappears.

In case of a secondary-side supply undervoltage, the corresponding power semiconductor is driven with a negative gate voltage to keep it in the off-state (the channel is blocked) and a fault condition is transmitted to the corresponding SO_x output. The SO_x output is automatically reset (returning to a high impedance state) after the blocking time.

V_{CE} monitoring / short-circuit protection

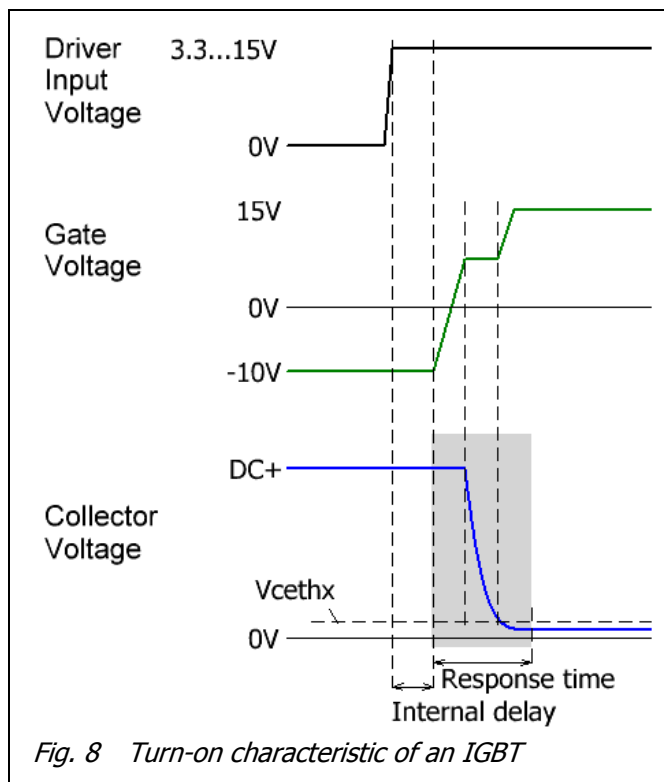

Each channel of the 2SC0535T driver is equipped with a V_{CE} monitoring circuit. The recommended external circuitry is shown in Fig. 7. The resistor R_{thx} can be used to define the static turn-off threshold together with R_{vceix} and R_{divx}. It is recommended to choose threshold levels of about 10.2V for 1700V IGBTs and 50V for 3300V IGBTs. In this case, the driver will safely protect the IGBT against short circuit, but not necessarily against overcurrent. Overcurrent protection has a lower timing priority and it is recommended to implement it within the host controller.

During the response time, the V_{CE} monitoring circuit is inactive. The response time is the time that elapses after turn-on of the power semiconductor until the collector voltage is measured (see Fig. 8).

Both IGBT collector-emitter voltages are measured individually. V_{CE} is checked after the response time at turn-on to detect a short circuit or overcurrent. If the measured V_{CE} at the end of the response time is higher than the threshold V_{CEthx}, the driver detects a short circuit

or overcurrent. The driver then turns the corresponding power semiconductor off. The fault status is immediately transferred to the corresponding SO_x output of the affected channel. The power semiconductor

Preliminary Description & Application Manual

is kept in the off state (non-conducting) and the fault is shown at pin SOx as long as the blocking time T_b is active.

The blocking time T_b is applied independently to each channel. T_b starts as soon as V_{CE} exceeds the threshold of the V_{CE} monitoring circuit outside the response time span.

Desaturation protection with sense diodes

If desaturation protection with sense diodes is required with the 2SC0535T, please refer to the Application Note AN-1101 /4/. Note that desaturation protection with sense diodes is not recommended for IGBT modules with voltage classes >1700V.

Parallel connection of 2SC0535T

If parallel connection of 2SC0535T drivers is required, please refer to the application note AN-0904 /5/.

3-level or multilevel topologies

If 2SC0535T drivers are to be used in 3-level or multilevel topologies, please refer to the Application Note AN-0901 /6/.

Bibliography

- /1/ Paper: Smart Power Chip Tuning, Bodo's Power Systems, May 2007
- /2/ "Description and Application Manual for SCALE™ Drivers", Power Integrations
- /3/ Data sheet SCALE™-2 driver core 2SC0535T, Power Integrations
- /4/ Application note AN-1101: Application with SCALE™-2 Gate Driver Cores, Power Integrations
- /5/ Application note AN-0904: Direct Paralleling of SCALE™-2 Gate Driver Cores, Power Integrations
- /6/ Application note AN-0901: Methodology for Controlling Multi-Level Converter Topologies with SCALE™-2 IGBT Drivers, Power Integrations

Note: The Application Notes are available on the Internet at www.power.com/igbt-driver/go/app-note and the papers at www.power.com/igbt-driver/go/papers

Preliminary Description & Application Manual

The Information Source: SCALE-2 Driver Data Sheets

Power Integrations offers the widest selection of gate drivers for power MOSFETs and IGBTs for almost any application requirements. The largest website on gate-drive circuitry anywhere contains all data sheets, application notes and manuals, technical information and support sections: www.power.com

Quite Special: Customized SCALE-2 Drivers

If you need an IGBT driver that is not included in the delivery range, please don't hesitate to contact Power Integrations or your Power Integrations sales partner.

Power Integrations has more than 25 years experience in the development and manufacture of intelligent gate drivers for power MOSFETs and IGBTs and has already implemented a large number of customized solutions.

Technical Support

Power Integrations provides expert help with your questions and problems:

www.power.com/igbt-driver/go/support

Quality

The obligation to high quality is one of the central features laid down in the mission statement of Power Integrations Switzerland GmbH. Our total quality management system assures state-of-the-art processes throughout all functions of the company, certified by ISO9001:2008 standards.

Legal Disclaimer

The statements, technical information and recommendations contained herein are believed to be accurate as of the date hereof. All parameters, numbers, values and other technical data included in the technical information were calculated and determined to our best knowledge in accordance with the relevant technical norms (if any). They may base on assumptions or operational conditions that do not necessarily apply in general. We exclude any representation or warranty, express or implied, in relation to the accuracy or completeness of the statements, technical information and recommendations contained herein. No responsibility is accepted for the accuracy or sufficiency of any of the statements, technical information, recommendations or opinions communicated and any liability for any direct, indirect or consequential loss or damage suffered by any person arising therefrom is expressly disclaimed.

Preliminary Description & Application Manual

Ordering Information

The general terms and conditions of delivery of Power Integrations Switzerland GmbH apply.

Type Designation	Description
2SC0535T2A0-33	Dual-channel SCALE-2 driver core (not recommended for new designs)
2SC0535T2A1-33	Dual-channel SCALE-2 driver core (lead free)

Product home page: www.power.com/igbt-driver/go/2SC0535T

Refer to www.power.com/igbt-driver/go/nomenclature for information on driver nomenclature

Information about Other Products

For other driver cores:

Direct link: www.power.com/igbt-driver/go/cores

For other drivers, product documentation, evaluation systems and application support

Please click onto: www.power.com

Manufacturer

Power Integrations Switzerland GmbH
Johann-Renfer-Strasse 15
2504 Biel-Bienne, Switzerland

Phone +41 32 344 47 47
Fax +41 32 344 47 40
Email igbt-driver.sales@power.com
Website www.power.com/igbt-driver

© 2011...2015 Power Integrations Switzerland GmbH.

We reserve the right to make any technical modifications without prior notice.

All rights reserved.
Version 2.1 from 2015-05-28

Preliminary Description & Application Manual

Power Integrations Worldwide High Power Customer Support Locations

World Headquarters

5245 Hellyer Avenue
San Jose, CA 95138 | USA
Main +1 408 414 9200
Customer Service:
Phone +1 408 414 9665
Fax +1 408 414 9765
Email usasales@power.com

Switzerland (Biel)

Johann-Renfer-Strasse 15
2504 Biel-Bienne | Switzerland
Phone +41 32 344 47 47
Fax +41 32 344 47 40
Email igbt-driver.sales@power.com

Germany (Ense)

HellwegForum 1
59469 Ense | Germany
Phone +49 2938 643 9990
Email igbt-driver.sales@power.com

Germany (Munich)

Lindwurmstrasse 114
80337 Munich | Germany
Phone +49 895 527 39110
Fax +49 895 527 39200
Email eurossales@power.com

China (Shanghai)

Rm 2410, Charity Plaza, No. 88
North Caoxi Road
Shanghai, PRC 200030
Phone +86 21 6354 6323
Fax +86 21 6354 6325
Email chinasales@power.com

China (Shenzhen)

17/F, Hivac Building, No 2,
Keji South 8th Road,
Nanshan District
Shenzhen | China, 518057
Phone +86 755 8672 8725
Fax +86 755 8672 8690
Hotline +86 400 0755 669
Email chinasales@power.com

Italy (Milano)

Via Milanese 20, 3rd. Fl.
20099 Sesto San Giovanni | Italy
Phone +39 024 550 8701
Fax +39 028 928 6009
Email eurossales@power.com

UK (Herts)

First Floor, Unit 15, Meadway Court,
Rutherford Close, Stevenage,
Herts SG1 2EF | United Kingdom
Phone: +44 1252 730 141
Fax +44 1252 727 689
Email eurossales@power.com

India (Bangalore)

#1, 14th Main Road
Vasanthanagar
Bangalore 560052 | India
Phone +91 80 4113 8020
Fax +91 80 4113 8023
Email indiasales@power.com

Japan (Kanagawa)

Kosei Dai-3 Bldg., 2-12-11, Shin-
Yokohama, Kohoku-ku, Yokohama-shi,
Kanagawa 222-0033 | Japan
Phone +81 45 471 1021
Fax +81 45 471 3717
Email japansales@power.com

Korea (Seoul)

RM 602, 6FL
Korea City Air Terminal B/D, 159-6
Samsung-Dong, Kangnam-Gu
Seoul 135-728 | Korea
Phone +82 2 2016 6610
Fax +82 2 2016 6630
Email koreasales@power.com

Taiwan (Taipei)

5F, No. 318, Nei Hu Rd., Sec. 1
Nei Hu Dist.
Taipei 11493 | Taiwan R.O.C.
Phone +886 2 2659 4570
Fax +886 2 2659 4550
Email taiwansales@power.com